

# **KUSTOM**

## **KPM7200**

### **Owner's Manual**

Congratulations, you now own Kustom's KPM7200 Powered Mixer, a 24-bit digital, portable and powerful 200 Watt PA mixer/amplifier.

The Kustom KPM7200 is easy to operate and easy to understand. Before operating your KPM7200, please read and understand all setup and safety instructions.

# ENGLISH

## Danger

Exposure to extremely high noise levels may cause a permanent hearing loss. Individuals vary considerably to noise induced hearing loss but nearly everyone will lose some hearing if exposed to sufficiently intense noise for a sufficient time.

The U.S. Government's Occupational Safety and Health Administration (OSHA) has specified the following permissible noise level exposures:

DURATION PER DAY (HOURS)	8	6	4	3	2	1
SOUND LEVEL (dB)	90	93	95	97	100	103

According to OSHA, any exposure in the above permissible limits could result in some hearing loss. Ear plugs or protectors in the ear canal or over the ears must be worn when operating this amplification system in order to prevent a permanent hearing loss. If exposure in excess of the limits as put forth above, to insure against potentially harmful exposure to high sound pressure levels, it is recommended that all persons exposed to equipment capable of inducing high sound pressure levels, such as this amplification system, be protected by hearing protectors while this unit is in operation.

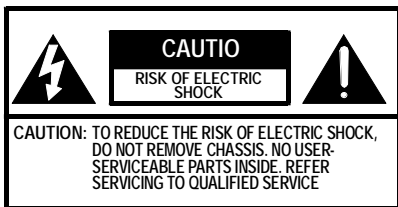

AVIS: RISQUE DE CHOC ELECTRIQUE-NE PAS



THIS SYMBOL IS INTENDED TO ALERT THE USER TO THE PRESENCE OF NON-INSULATED "DANGEROUS VOLTAGE" WITHIN THE PRODUCT'S ENCLOSURE THAT MAY BE OF SUFFICIENT MAGNITUDE TO CONSTITUTE A RISK OF ELECTRIC SHOCK TO PERSONS.



THIS SYMBOL IS INTENDED TO ALERT THE USER TO THE PRESENCE OF IMPORTANT OPERATING AND MAINTENANCE (SERVICING) INSTRUCTIONS IN THE LITERATURE ACCOMPANYING THE UNIT.

### IMPORTANT

1. Read all safety and operating instructions before using this product.
2. All safety and operating instructions should be kept for future reference.
3. This product should not be used near water i.e. bathtub, sink, swimming pool, wet basement, etc.
4. This product should be located so that its position does not interfere with proper ventilation. It should not be placed flat against a wall or placed in a built-in enclosure that will impede the flow of cooling air.
5. This product should not be placed near a source of heat, such as a stove, radiator, or another heat producing amplifier.
6. Connect only to a power supply of the type indicated on the back of the amplifier near the power supply cord.
7. Do not break off the ground pin of the power supply cord.
8. Power supply cords should always handled carefully. Never walk or place equipment on power supply cords.
9. The power supply cord should be unplugged when the unit is unused for long periods of time.
10. Care should be taken so that objects do not fall and liquids are not spilled into the unit through the ventilation ports or any other openings.

# FRENCH

## Danger

L'exposition a des niveaux eleves de bruit peut provoquer une perte permanente de l'audition. Chaque organisme humain reagit differemment quant a la perte de l'audition, mais quasiment tout le monde subit une diminution de l'acuite auditive lors d'une exposition suffisamment longue au bruit intense. Les autorites competentes en reglementation de bruit ont defini les expositions tolerees aux niveaux de bruits:

DURE EN HEURES PAR JOUR	8	6	4	3	2	1
NIVEAU SONORE CONTINU EN dB	90	93	95	97	100	103

Selon les autorites, toute exposition dans les limites citees ci-dessus, peuvent provoquer certaines pertes d'audition. Des bouchons ou protections dans l'appareil auditif ou sur l'oreille doivent etre portes lors de l'utilisation de ce systeme d'amplification afin de prevenir le risque de perte permanente de l'audition. Dans le cas d'expositions superieures aux limites precitees il est recommande, afin de se premunir contre les expositions aux pressions acoustiques elevees potentiellement dangeereuses, aux personnes exposees aux equipements capables de delivrer de telles puissances, tels ce systeme d'amplification en fonctionnement, de proteger l'appareil auditif.



CE SYMBOLE A POUR BUT D'AVERTIR L'UTILISATEUR DE LA PRESENCE DE VOLTAGE DANGEREUX NON-ISOLE A L'INTERIEUR DE CE PRODUIT QUI PEUT ETRE DE PUISSANCE SUFFISAMMENT IMPORTANTE POUR PROVOQUER UN CHOC ELECTRIQUE AUX PERSONNES.



CE SYMBOLE A POUR BUT D'AVERTIR L'UTILISATEUR DE LA PRESENCE D'INSTRUCTIONS D'UTILISATION ET DE MAINTENANCE DANS LES DOCUMENTS FOURNIS AVEC CE PRODUIT.

### IMPORTANT

1. Lisez toutes les instructions d'utilisation et de sécurité avant d'utiliser ce produit.
2. Toutes les instructions d'utilisation et de sécurité doivent être conservées afin de pouvoir s'y référer à tout moment.
3. Cet appareil ne doit pas être utilisé à proximité d'eau ou baignoire, évier, piscine, sous-sol humide, etc.
4. Cet appareil doit être placé de telle sorte que sa position ne l'empêche pas d'être ventilé. Il ne doit pas être placé à plat contre un mur ou dans un espace encastré qui empêcherait la ventilation.
5. Cet appareil ne doit pas être placé près d'une source de chaleur tel un fourneau, radiateur ou tout autre appareil produisant de la chaleur.
6. Branchez uniquement une alimentation électrique du type indiqué sur l'arrière de l'amplificateur, près du cordon d'alimentation électrique.
7. Ne coupez pas la borne de terre du cordon d'alimentation électrique.
8. Les cordons d'alimentation électrique doivent toujours être manipulés avec précaution. Ne jamais marcher ni poser un équipement sur des cordons d'alimentation électrique.
9. Le cordon d'alimentation électrique doit être débranché en cas de période de non-utilisation prolongée.
10. Il faut prendre les précautions nécessaires afin de ne pas faire tomber d'objet ni renverser du liquide dans l'appareil par les trous d'aération ou toute autre ouverture.

# SETUP DIAGRAM A MIXER FRONT

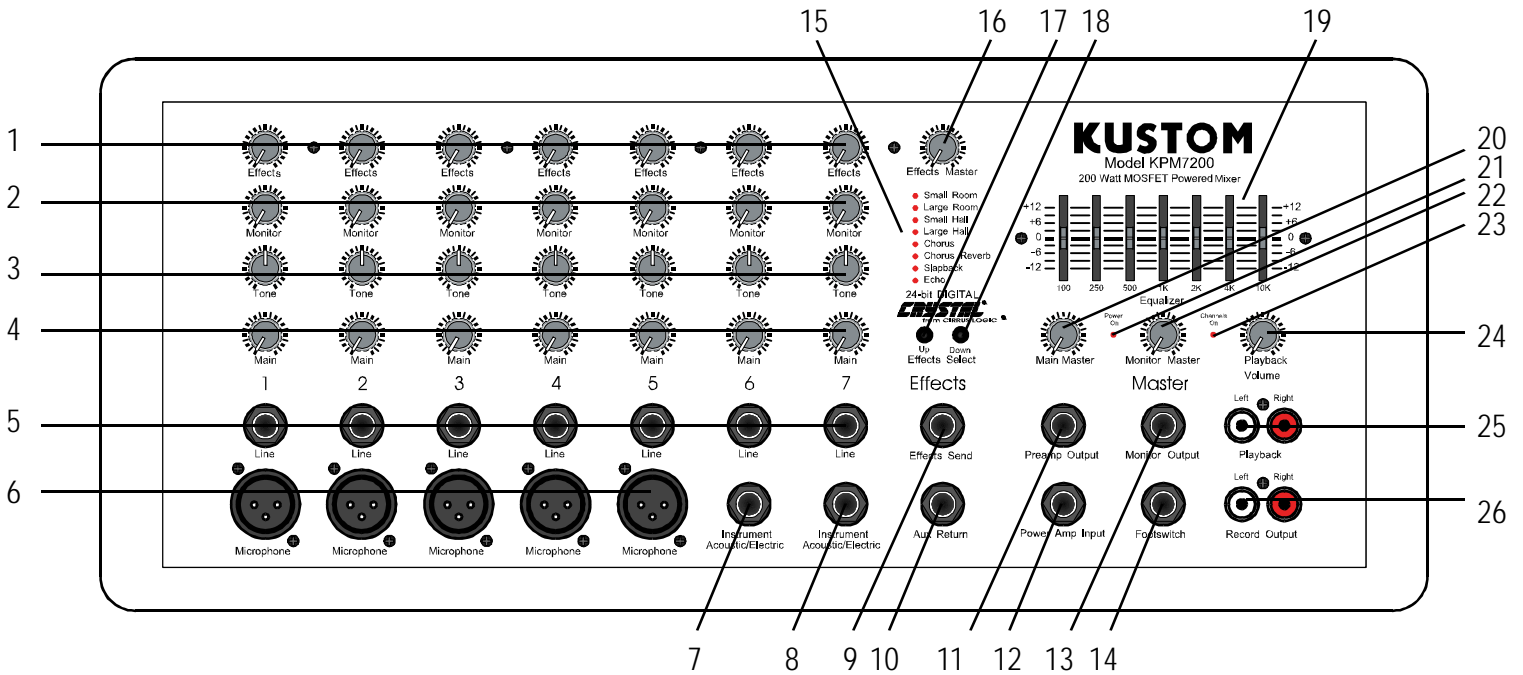

# SETUP DIAGRAM B MIXER REAR

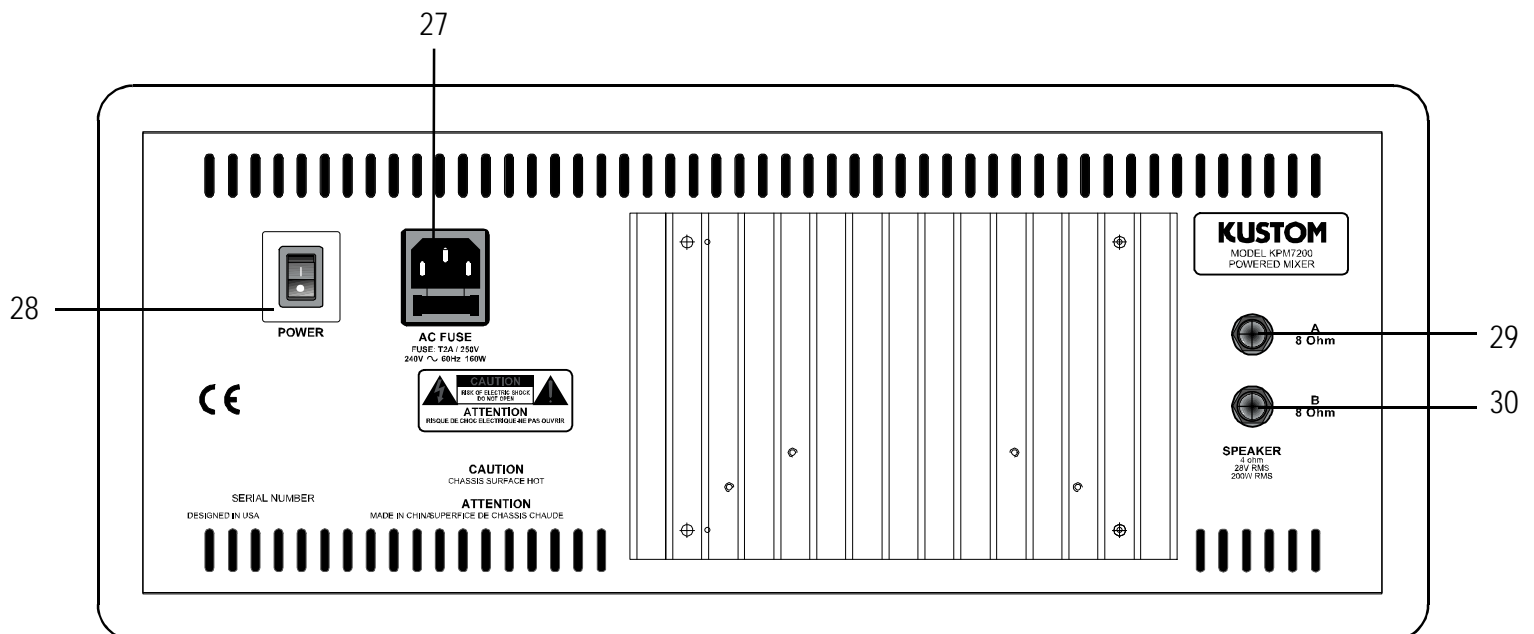

## EXPLANATION OF CONTROLS

### FRONT PANEL

- 1) **Effects Controls:** Adjusts the amount of signal that is sent to the digital effects processor.
- 2) **Monitor Controls:** Adjusts the amount of signal that is sent to the Master Monitor control.
- 3) **Tone Controls:** Adjusts the balance of bass and treble from the individual channels.
- 4) **Main Controls:** Adjusts the volume of the individual channel.
- 5) **Line Input:** Input connection for 1/4" line level sources (Keyboards, drum machines, etc.)
- 6) **Microphone Input:** Input connection for balanced Low-Z signals (Microphones, etc.)
- 7-8) **Instrument Inputs:** Input connection for instruments (Acoustic Guitars, Electric Guitars, etc.)
- 9) **Effects Send:** Output connector used to send a line level signal from the KPM7200 to an outboard effect. This connector takes a signal feed from the individual channel's Effects controls.
- 10) **Aux Return:** Input connector used to receive a signal from an outboard effect or signal source. The signal from this connector is fed to the effect Master (16) control. The Effect Master control (16) will adjust the volume of this signal source.
- 11) **Preamp Output:** Line level output for the preamp. This control takes a signal feed from the Main Master control.
- 12) **Power Amp Input:** Input connector for the Power Amp. NOTE: When a line level signal source is inserted into this connector, the signal from the Kustom KPM7200's individual channels are disconnected and will not function. Only the outboard signal source will be amplified.
- 13) **Monitor Output:** Output connector to send a line level signal to a monitor amplifier or powered monitor.
- 14) **Footswitch:** Standard Tip-Ring-Sleeve wired footswitch to turn digital effects on and mute the channels of the KPM7200. Tip connection turns the Effects on and off. The Ring connection will mute the individual channels.
- 15) **Digital Effects Indicators:** These LED's show what digital effects have been chose. NOTE: No LED's are lit when the Effects are muted via footswitch.
- 16) **Effects Master:** Controls the volume of digital effect signal to the Main Master control.
- 17-18) **Effect Select:** These two push buttons will scroll through the digital effect options. Pressing the UP button will advance the digital effect selection to the next selection higher than the present selection. Pressing the DOWN button will advance the digital effect selection to the next selection lower than the present selection. NOTE: When scrolling past the top or bottom of the effects selection, the effects selection will automatically go to the opposite end of the selections.
- 19) **Equalizer:** These controls adjust overall tone of the mixer. Each slide control adjusts the amount of specific frequencies + or - 12dB.
- 20) **Main Master:** Controls the total volume on the individual channels. NOTE: The playback volume is not affected by the Main Master control.
- 21) **Power On Indicator:** Power is on when LED is lit.
- 22) **Monitor Master:** Controls the total volume of the individual channel's monitor sends. NOTE: The Monitor output is still active when Main channels are muted via footswitch.

- 23) **Channels On Indicator:** Channels are active when LED is lit.
- 24) **Playback Volume:** Controls the volume from the Playback RCA input jacks (25).  
NOTE: The Playback feature is not affected by the Main Master control and will remain active even when the mute function is active via the footswitch.
- 25) **Playback RCA Jacks:** Input connector CD, Tape or any line level stereo signal source.  
Allows you to play recorded music through the mixer.
- 26) **Record RCA Jacks:** Output connectors to send line level signal to a record device such as a tape recorder or computer.

## REAR PANEL

- 27) **AC Cord Connector:** Insert the AC cord (supplied) firmly into the AC connector. NOTE: Replace the AC power cord if protective jacket is damaged or round ground pin is damaged or removed.
- 28) **Power Switch:** The KPM7200 is turned ON when the switch is in the UP position.  
Press the switch to the DOWN position when not in use.
- 29-30) **Speaker:** Connectors for 8 Ohm speaker cabinets each.  
NOTES: #1 do not connect more than two 8 Ohm speaker cabinets to the output of the KPM7200 mixer/amplifier.  
Total load must not go below 4 Ohms.  
#2. It is not necessary to use both A & B output jacks.  
The KPM7200 will operate at 8-16 Ohms.

## QUICK-START SETUP INSTRUCTIONS

### Making Connections:

- Connect 1/4" non-shielded speaker cables to the speaker out jacks on the rear of the KPM7200 (29 & 30), then connect the opposite end of each speaker cable to the speaker enclosures.
- Connect instruments and microphones into the appropriate input connectors located on the front of the mixer. Low Impedance Microphones (6), Line Level (5), High Impedance Instruments (7 & 8), tape/CD (25).
- Make sure the power switch is turned to the off position and attach the AC power cable into the fused AC input (27) located on the rear of the mixer.

### Master Section:

- Turn the Main Master control (20), and Playback Master (24) counter clockwise.
- Adjust the master equalizer slide controls (19) to the center 0dB position.

### Input Section:

- Turn all channel volume controls (4) counter clockwise.
- Turn all tone controls (3) to the 12 O'clock position.

## PLAYING

- Press the Power switch (28) to the ON position.
- Turn the Main Master control (20) to the 12 O'clock position.
- Turn the Main control (4) clockwise on each channel to achieve the desired volume. (One channel at a time)
- After you are satisfied with the basic mix of the individual channels, use the Main Master control (20) to adjust the overall volume of the mixer.
- Use the Graphic Equalizer slide controls (19) to control feedback and contour the audio to the overall desired sound.
- Select a digital effect (if desired). The KPM7200 offers a choice of eight 24-bit digital effects.

### STAGE EFFECTS

Large Room  
Small Room  
Small Hall  
Large Hall

### STUDIO EFFECTS

Chorus  
Chorus / Reverb  
Slap-back Echo  
Delay

- Adjust the effects controls on the individual channels (1) to desired volume.  
Adjust the effects Master control to achieve the total desired amount of effects in the mix.
- Reset the Main master control (20) to desired volume.

That's it. Enjoy...

Servicing: The AC Fuse is accessible underneath the AC cable connector. No user serviceable parts inside. Please contact your nearest Authorized Kustom Service Center or Kustom Inc. directly for service.

Kustom Inc. Customer Service can be reached at (513) 451-5000 ext. 504, [service@kustom.com](mailto:service@kustom.com) or locate an Authorized Service Center from the World Wide Web at [www.kustom.com](http://www.kustom.com).

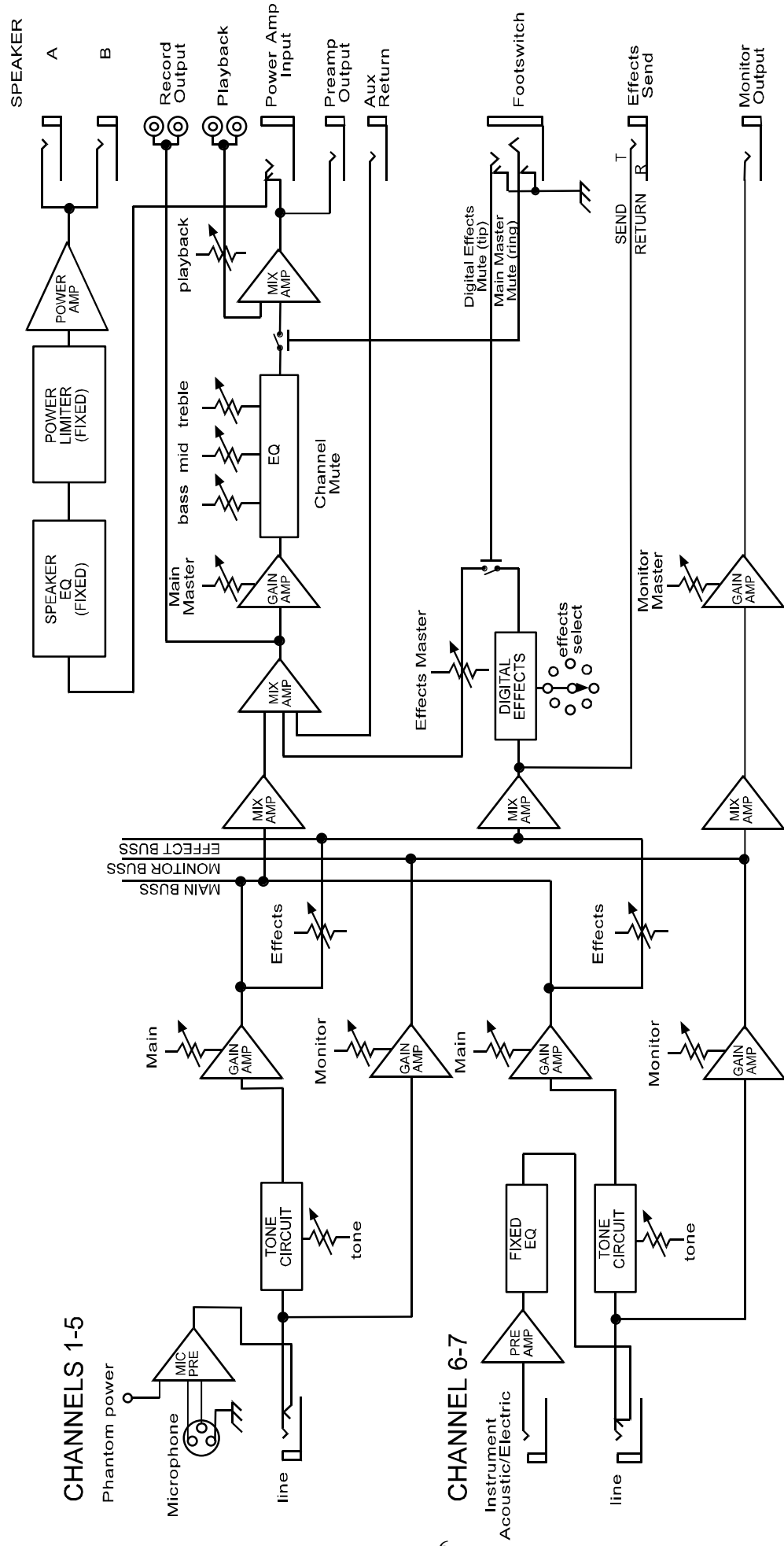

# SIGNAL FLOW DIAGRAM

# KPM7200

## Specifications

Model	KPM7200	KPM7200 Powered Mixer
Output Power	200W	4 ohms @ 5% THD
	160W	4 ohms @ 0.4% THD
Frequency Response	20Hz-20kHz	Actual response is tailored to speaker cabinet for accurate acoustical response.
Total Harmonic Distortion	less than 0.4%	Measured at 1VRMS (0dBv) at record output, effects send, or insert output
Hum & Noise	-115dB	Mic Input, Rs=150 ohm, 20-20kHz
	-60dB	Residual Noise, all level controls 0% (minimum)
	-50dB	Nominal System Noise, all level controls at 50%
System Gain	All measurements made at 1kHz	
	77dB	Mic to Power Amp Out (Ch 1 - Ch 5)
	60dB	Line to Power Amp Out (Ch 1 - Ch 7)
	70dB	Instrument to Power Amp (Ch 6 - Ch 7)
	36dB	Playback to Power Amp
	50dB	Mic to Record Output
	44dB	Mic to Effects Send
	50dB	Mic to Preamp Output
	50dB	Mic to Monitor Output
Crosstalk	80dB	Channel to channel, 1kHz
Input Channel Equalization	Special curve that adjusts bass, mid, and treble frequencies	
Master Equalization	100 to 10KHz, 7 Band, 1 Octave Graphic, all $\pm 12$ dB	
Digital Effects	24 bit DSP, 8 effects; small room, large room, small hall, large hall, chorus, chorus reverb, slap back (delay), echo	
Phantom Power	+15V	Applied to all Mic Inputs thru 3.3K resistors
Footswitch	Digital effects ON/OFF and Channel ON/OFF (playback remains active)	
Power Requirements	USA/Canada	120VAC/60Hz, 160W nominal
	Europe	230VAC/50Hz, 160W nominal
	UK	230VAC/50Hz, 160W nominal
	Australia	240VAC/50Hz, 160W nominal
	Japan	100VAC/50-60Hz, 160W nominal
Dimensions	mm/kg	210 (Height) x 480 (Width) x 270 (Depth), 11 kg
	inches/pounds	8 1/4 (Height) x 19 (Width) x 10 5/8 (Depth), 24 lbs



# EC Declaration of Conformity

We: Kustom Musical Amplification Inc.  
4940 Delhi Pike  
Cincinnati, OH 45238  
Tel: 1-513-451-5000 Fax: 1-513-347-2298  
www.kustom.com

Declare that the product

Product name: Kustom

Product model number: KPM7200, Contains one KPM7200

to which this declaration relates is in conformity with the following standards;

EN55013 (A12) : 1995	Limits and methods of measurement of radio disturbance characteristics of broadcast receivers and associated equipment.
EN55020: 1995	Electromagnetic immunity of broadcast receivers and associated equipment.
EN61000-3-2: 1995	Limits for harmonic current emissions (equipment input current $\leq$ 16A per phase).
EN61000-3-3: 1995	Limitation of voltage fluctuations and flicker in low voltage supply systems for equipment with rated currents $\leq$ 16A.
EN55103-1: 1995	Electromagnetic Compatibility - Product family standard for Audio, Video Audio-visual and entertainment Lighting Control Apparatus.
EN60065: 1994	Safety requirements for main operated electronic and related apparatus for household and similar general use.

Following the provisions of EU Council Directive(s): 72/73 EEC and 89/336/EEC.

We the undersigned, hereby declare that the equipment specified above conforms to the aforementioned directive(s).

Name of authorized person: Rick Kukulies, VP Engineering

Signature



Date: 05 June 2001

**KUSTOM** Kustom Inc., 4940 Delhi Pike, Cincinnati, OH • USA  
(800) 999-5558 Fax: (513) 347-2192 / [www.kustom.com](http://www.kustom.com)